

HAMMOND

Model XPK-200

Thank you, and congratulations on your choice of a Hammond XPK-200.

The XPK-200 is a 20-note MIDI Pedalboard.

In order to get the most out of this instrument for many years to come, please take the time to read this manual in full.

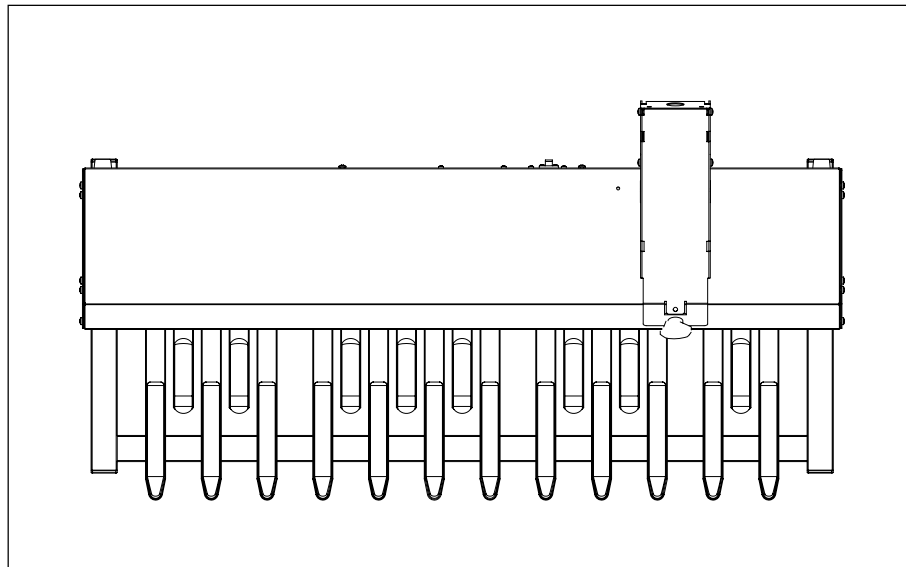

Owner's Manual

IMPORTANT SAFETY NOTICE

- ◆ Before using this unit, please carefully read these “Safety Instructions”.
- ◆ Please be sure to keep this manual at hand for future reference.
- ◆ This “Safety Instruction” section contains very important points for securing your safety.



WARNING This sign shows there is a risk of death or severe injury if this unit is not properly used as instructed.

Follow instructions:

All operation and user instructions should be followed.



Do Not Disassemble:

Do not disassemble this unit.



Servicing:

The user should not attempt to service the appliance beyond that is described in the Operation Instructions. All other servicing should be referred to qualified service personnel.



Location:

Using the unit in the following locations can result in a malfunction.

- ◆ In direct sunlight
- ◆ Locations of extreme temperature or humidity
- ◆ Excessively dusty or dirty locations
- ◆ Locations of excessive vibration
- ◆ Close to magnetic fields



Placement:

Do not place on a non-stable stand or a listing place. Set on a stable horizontally place.



Object and Liquid Entry:

Care should be taken so that objects do not fall and liquids are not spilled into the enclosure through the openings.



Damage Requiring Service:

The appliance should be serviced by qualified service personnel when:

- ◆ The power supply cord or the plug has been damaged; or
- ◆ Objects have fallen, or liquid has been spilled into the appliance; or
- ◆ The appliance has been exposed to rain; or
- ◆ The appliance does not appear to operate normally or exhibits a marked change in performance; or
- ◆ The appliance has been dropped, or the enclosure damaged.



Children:

If you let your children use this unit, please always watch and guide them and do not leave them alone.



Do Not Cause a Shock

Do not drop or cause a shock to this unit.

**CAUTION**

This sign shows that there is a risk of injury or material damage if this unit is not properly used as instructed.

*Material damage here means damage to the room, furniture or animals or pets.

**Keep Away from Extreme Heat:**

Do not use, leave or store this unit in an automobile or near heating apparatuses that emit extreme heat. This may cause deformation or damages to this unit.

**Stack/Ride:**

Do not stack heavy devices or sit on this unit. This may cause personal injuries.

**Detach the Expression Pedal, Connection Cables, etc. before moving:**

Before you move/transport this unit, detach the Expression Pedal and all the connection cables. Otherwise, the cables maybe damaged which may cause fire or electrical shock.

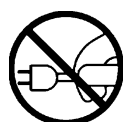
**Do Not Pull the AC adaptor Cord:**

Be sure to grasp the AC adaptor when unplugging it from a wall outlet. Pulling on the power cord can damage it, and create the danger of fire and electrical shock.

**Handling Cables:**

Do not entangle the cables. Always keep them away from children's reach.

**Care:**

If the exterior becomes dirty, wipe it with a clean, dry cloth. Do not use liquid cleaners such as benzene or thinner, or cleaning compounds or flammable polishes.

**Hook Up:**

Turn off all devices before hook up. Follow all instructions and use only designated cables.

**Movable Parts:**

Be careful not to pinch your fingers when you assemble or disassemble this unit.

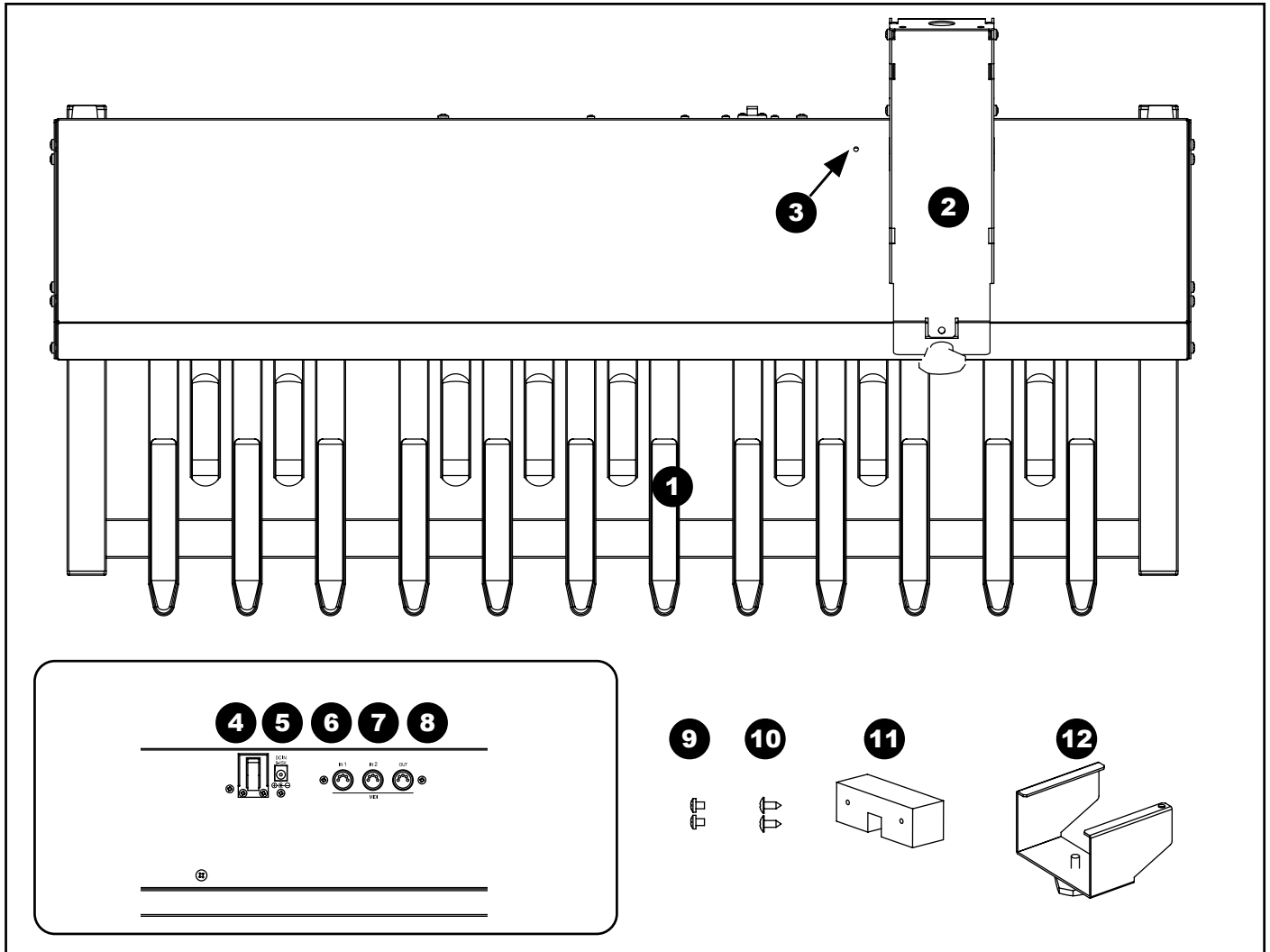

1. Pedal keyboard

20-note non-velocity pedal keyboard.

2. Expression Bracket 1

This bracket is a base for mounting the optional Expression Pedal EXP-100F or V-20R.

3. LED

This LED dimly lights when the power is ON. It also indicates the playing status of the pedal keyboard (lights up when being played) and the MIDI channel.

4. Cord Hook

Hook the AC Adaptor Cord or the DCC-2 Cable on this to provide a strain relief.

5. DC IN Jack

This jack connects the attached AC Adaptor AD1-1508 (or AD3-1508) or DCC-2 Cable.

6. MIDI IN 1 Jack

This is a MIDI input Jack. MIDI signals received at this input will be merged with the playing information of the Pedalboard and sent out the MIDI OUT jack.

7. MIDI IN 2 Jack

This is also a MIDI input Jack. MIDI signals received at this input will be merged with the playing information from MIDI IN 1 and the playing information of the Pedalboard and sent out the MIDI OUT jack.

8. MIDI OUT Jack

This jack sends out the playing information of the Pedalboard as well as any merged information from MIDI IN 1 or 2.

9. M4 x 5 Screw (2)

Use these screws for attaching the Expression Pedal EXP-100F to Expression Bracket 1.

10. ø4 x 8 Screw (2)

Use these screws for attaching the Bracket Spacer.

11. Bracket Spacer

12. Expression Bracket 2

These (11 and 12) are used together with the Expression Bracket 1 for attaching the Expression Pedal V-20R.

◆ Mounting the EXP-100F

By use of a #2 Phillips screwdriver, temporarily remove the screw as shown from the bottom of the EXP-100F. Place the EXP-100F on top of the Expression Bracket 1. Fasten the EXP-100F to the front of the bracket as shown using the 2 - M4 x 5mm screws supplied. Using the screw that you previously removed, fasten the EXP-100F to the bottom of the bracket as shown.

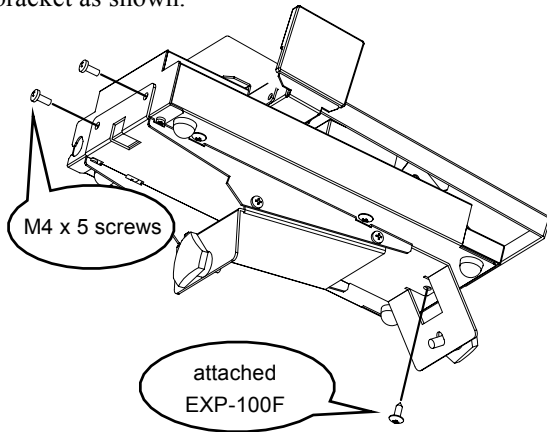

Place the Expression Bracket 1 on top of the XPK-200 as shown. Fasten the Bracket to the XPK-200 by turning the 2 knob bolts supplied clockwise.

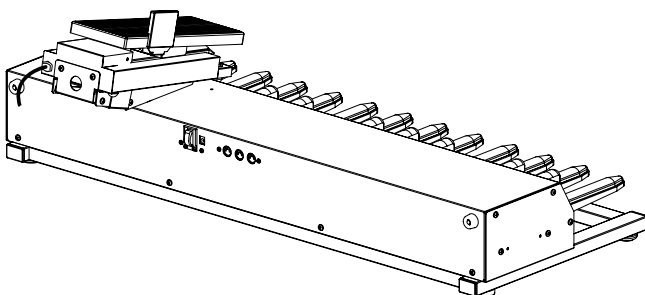
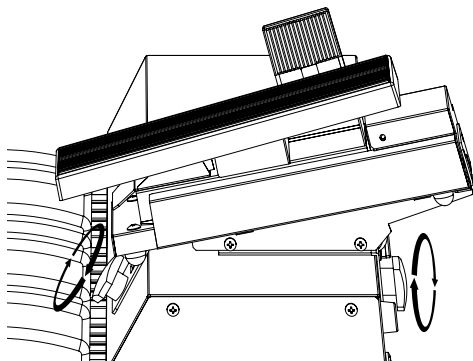

◆ Mounting the V-20R

Place the Expression Bracket 1 on top of the XPK-200 as shown. Fasten the Bracket to the XPK-200 by turning clockwise the 2 knob bolts supplied.

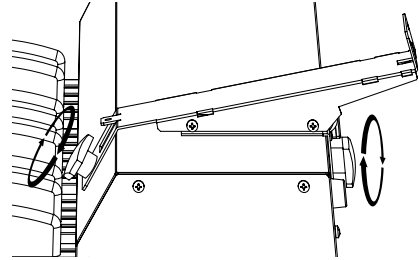

Place the V-20R on top of the Expression Bracket 1 and route the cord through the read hole in the Bracket as shown. Place the Bracket Spacer on the Expression Bracket 1 as shown and fasten the spacer to the bracket with a #2 Phillips screwdriver and 2 - $\varnothing 4 \times 8$ mm screws.

Fasten the V-20R to the Expression Bracket 1 by sliding the Expression Bracket 2 onto the Expression Pedal assembly as shown and turning clockwise with the knob bolt supplied.

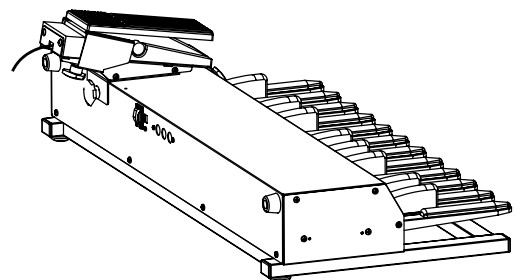
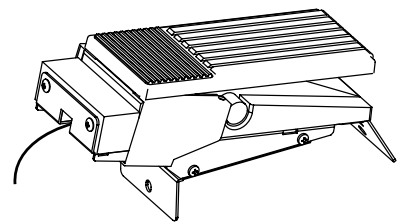
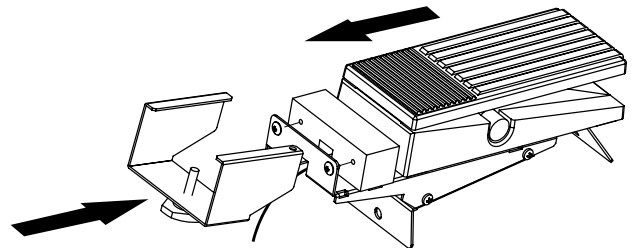

HOOK-UP

◆ An example of the Hook-up of the XE-1 and XLK-1

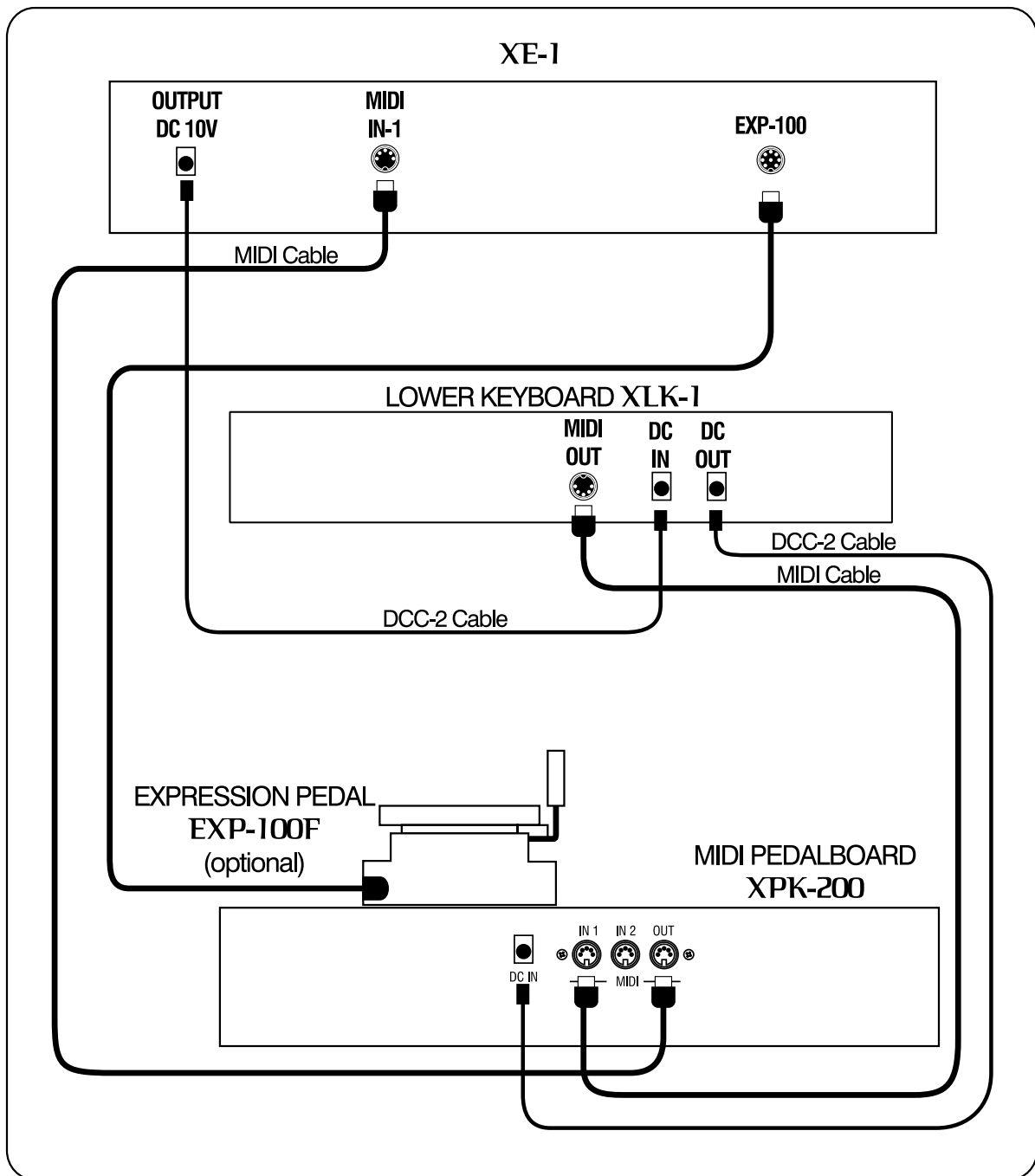

- ◆ Connect the MIDI OUT of the XLK-1 to the MIDI IN 1 of this unit by means of a MIDI cable.
- ◆ Connect the MIDI OUT of this unit to the MIDI IN 1 of the XE-1 by means of a MIDI cable.
- ◆ Connect the DC IN of this unit to the DC OUT of the XE-1 using the DCC-2 cable attached to the XLK-1. The AC adaptor is not used required for this hook-up.
- ◆ The playing information from the XLK-1 that's received at the MIDI IN 1 Jack on this unit is then merged with the playing information of this unit, and sent out of the MIDI OUT Jack on this unit.
- ◆ The power switch on the XE-1 switches the power on/off on this unit.

◆ A Hook-up example of the XK-3 and the XLK-3

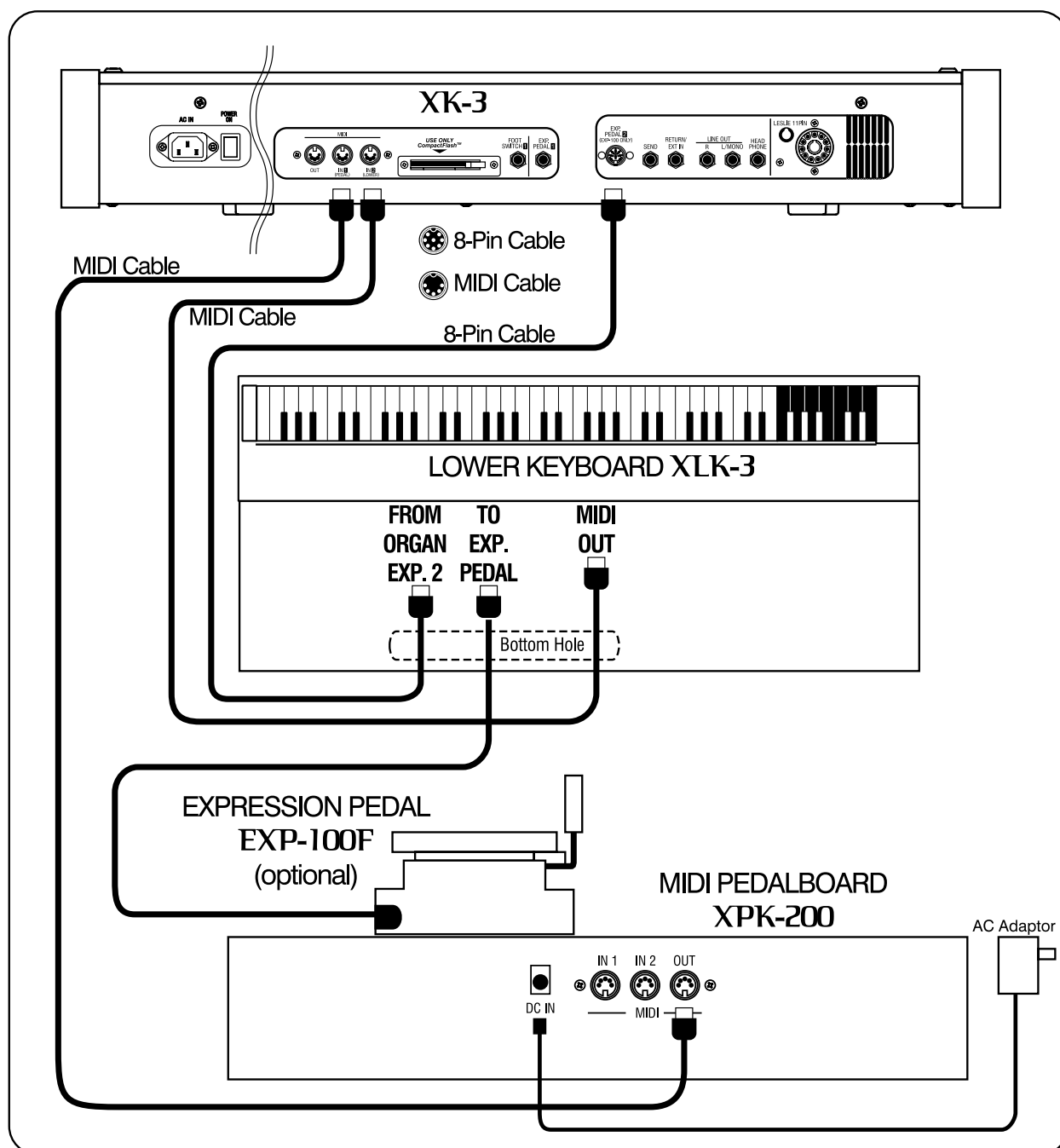

- ◆ Connect the MIDI OUT on this unit to the MIDI IN (PEDAL) of the XK-3 by means of a MIDI cable.
- ◆ Connect the AC adaptor AD1-1508/AD3-1508 to the DC IN on this unit.
- ◆ The power on this unit is not turned “On” or “Off” with the XK-3. Pull out the AC adaptor from the AC outlet after each use.

◆ A setting example of the XE-1

1. Switch ON the power of the XE-1.

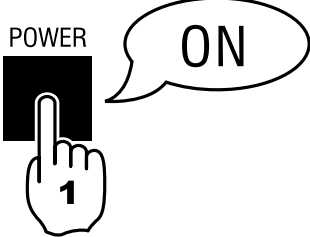

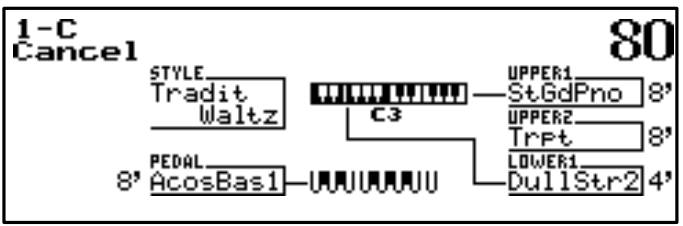

The PLAY mode is displayed on the LCD.

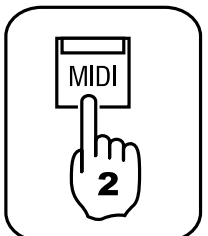

2. Touch the [MIDI] button.



3. Select SINGLE or DOUBLE according to the number of manuals that you are using.

4. Touch the Select Button 14 to set this setting.

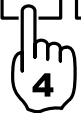

5. Touch the [PLAY] button and return to the PLAY mode.

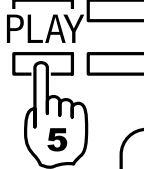

This completes the setting.
This setting is memorized, even after the power is switched off.

◆ A setting example of the XK-3

- 1.** Switch ON the power of the XK-3.

POWER



ON

PLAY mode is displayed on the LCD.
The light on the XLK-3 will also be turned ON when the XLK-3 is connected.

XK-3

C -B : 00 T+0

XLK-3



ON

2.

Touch the [MENU/EXIT] button.

MENU/EXIT



2

3.

Touch the [PAGE] button and move to Page D.

PAGE



3

DZONES BSETUP
BMIDI BCF FORM

2



4

4.

Touch the [2] MIDI button.

^TEMPLATE
Seq. Record▶ [RECL]



1

5



4

6

- 5.** Select "Seq.Record".

- 6.** Touch the [4] RECL button.

C -B : 00 T+0

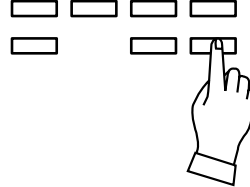

Touch the [PLAY] button to return to the PLAY mode.

This completes the setting.
This setting is memorized, even after the power is switched off.

◆ Setting the MIDI channel

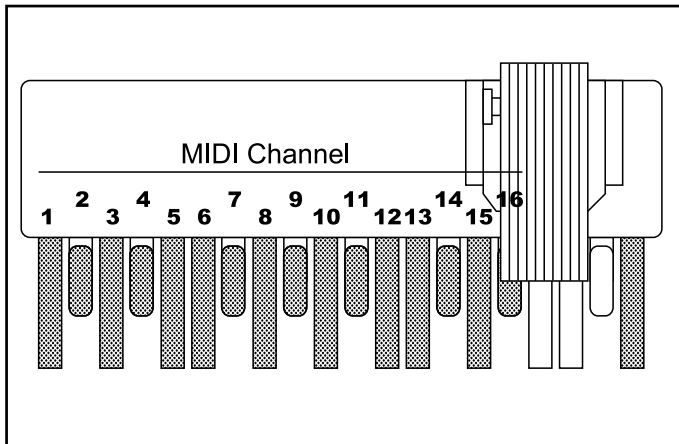

The factory default setting for the Pedalboard is channel 3. If you want to change it follow the procedure below:

Start with the power turned off. Turn on the power while holding down the highest G pedal **and** the pedal corresponding with the MIDI channel. (See the illustration on the left.) The LED light on this unit will blink the same number of times as the number of the MIDI channel selected. The setting is memorized and will remain in memory even if the power is turned off.

◆ Important Notes on MIDI Merge

This unit is equipped with the MIDI merge function. This feature allows MIDI playing information received at the MIDI IN jacks to be merged (blended) with the MIDI information from the Pedalboard and sent out the MIDI out jack.

PLEASE NOTE several points regarding this feature.

The MIDI messages to be merged

The MIDI merge function of this Pedalboard will only merge the channel messages. It does not merge such system message as system exclusive messages or MIDI clock.

Duplication of the MIDI channel

The Channels assigned to the MIDI INs must be different than the channel of the Pedalboard in order to provide proper music parts to the host keyboard.

The MIDI loop

If the MIDI information sent out of the MIDI OUT Jack of this Pedalboard returns to the MIDI in jack, a MIDI information loop happens and this causes a malfunction.

If the MIDI IN/OUT of this unit and those of the external equipment are connected, set the echo-back (MIDI thru) function or the local control function to correct the problem.

MIDI IMPLEMENTATION

[Hammond MIDI Pedalboard]
Model: XPK-200

MIDI Implementation Chart

Date: 4-Apr-2006
Version: 1.0

Function		Transmitted	Recognized	Remarks
Basic Channel	Default Changed	3 1 - 16	X	
Mode	Default Messages Altered	3 X *****	X X X	
Note Number	: True Voice	36 - 55 *****	X	
Velocity	Note ON Note OFF	X X	X X	
After Touch	Key's Ch's	X X	X X	
Pitch Bender		X	X	
Control Change		X	X	
Program Change	: True #	X *****	X X	
System Exclusive		X	X	
System Common	: Song Position : Song Select : Tune	X X X	X X X	
System Real Time	: Clock : Commands	X X	X X	
Aux Messages	: Local On/Off : All Notes Off : Active Sense : Reset	X X O X	X X X X	

Mode 1: OMNI ON, POLY
Mode 3: OMNI OFF, POLY

Mode 2: OMNI ON, MONO
Mode 4: OMNI OFF, MONO

O: Yes
X: No

Keyboard

20 notes non-velocity

ConnectionsDC IN
MIDI OUT
MIDI IN 1
MIDI IN 2**Dimension**872(W) x 400(D) x 133(H) mm
34.3(W) x 15.7(D) x 5.2(H) inch**Weight**13.5kg
29.8lbs**Accessory**AC Adaptor
AD1-1508 (100 - 120V)
AD3-1508 (220 - 240V)
Expression Bracket 1
Expression Bracket 2
Bracket Spacer
MIDI Cable (2.0m)
Screw M4 x 5mm (2pcs)
Screw ø4 x 8mm (2pcs)**SERVICE**

Hammond maintains a policy of continuously improving and upgrading its instruments and therefore reserves the right to change specifications without notice. Although every attempt has been made to insure the accuracy of the descriptive contents of this Manual, total accuracy cannot be guaranteed.

Should the owner require further assistance, inquiries should first be made to your Authorized Hammond Dealer. If you still need further assistance, contact Hammond at the following addresses:

In the United States contact:

HAMMOND SUZUKI USA, Inc.
733 Annoreno Dr.
Addison, IL 60101
UNITED STATES

Website:
www.hammondorganco.com

In Europe contact:

HAMMOND SUZUKI EUROPE
B.V.
IR. D.S. Tuynmanweg 4A
4131 PN Vianen
THE NETHERLANDS

E-mail: Info@hammondsuzuki.com
Website: www.hammondsuzuki.com

All other countries contact:

HAMMOND SUZUKI Ltd.
25-11, Ryoke 2 Chome
Hamamatsu 430-0852
(Shizuoka)
JAPAN

Website: www.suzuki-music.co.jp

Technical materials are available and can be obtained by mailing a request to the appropriate address listed above marked ATTENTION: SERVICE DEPARTMENT.

Manufacturer:
SUZUKI MUSICAL INSTRUMENT MFG. CO., Ltd.
25-12, Ryoke 2 Chome
Hamamatsu 430-0852 (Shizuoka)
JAPAN