

Contents

IMPORTANT SAFETY
INSTRUCTIONS
P.2

NAMES AND
FUNCTIONS
P.4

MOUNTING THE
EXPRESSION PEDAL
P.5

MAKING THE
CONNECTIONS
P.6

USING THE INTERNAL
SOUND GENERATOR
P.8

MIDI CHANNEL, MERGE
P.9

ADVANCED OPERATION
P.10

OTHERS
P.12

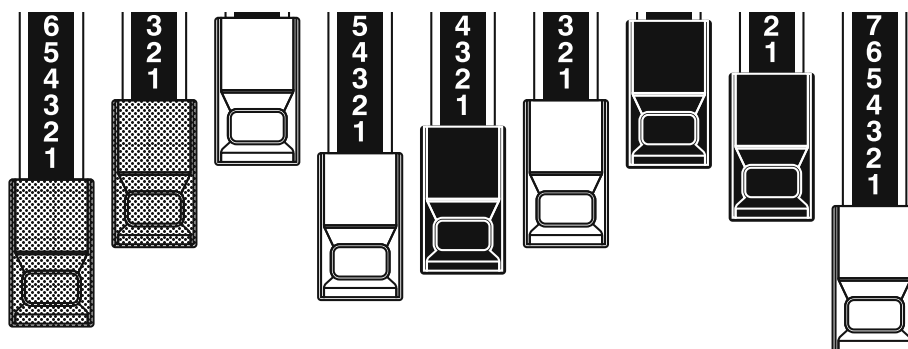

HAMMOND

MIDI SOUND PEDALBOARD

Model: **XPK-130G**

XPK-200G / 200GL

Thank you, and congratulations on your choice of a Hammond MIDI sound pedalboard!

The XPK-130G has 13 pedals (C to C), while the XPK-200G and XPK-200GL both have 20 pedals (C to G). In addition, the XPK-200GL has wooden naturals of extended length, to make "heel and toe" playing style easier.

In addition to the MIDI capabilities, these units also contain 5 built-in Pedal Voices, allowing you to use them as "stand-alone" units.

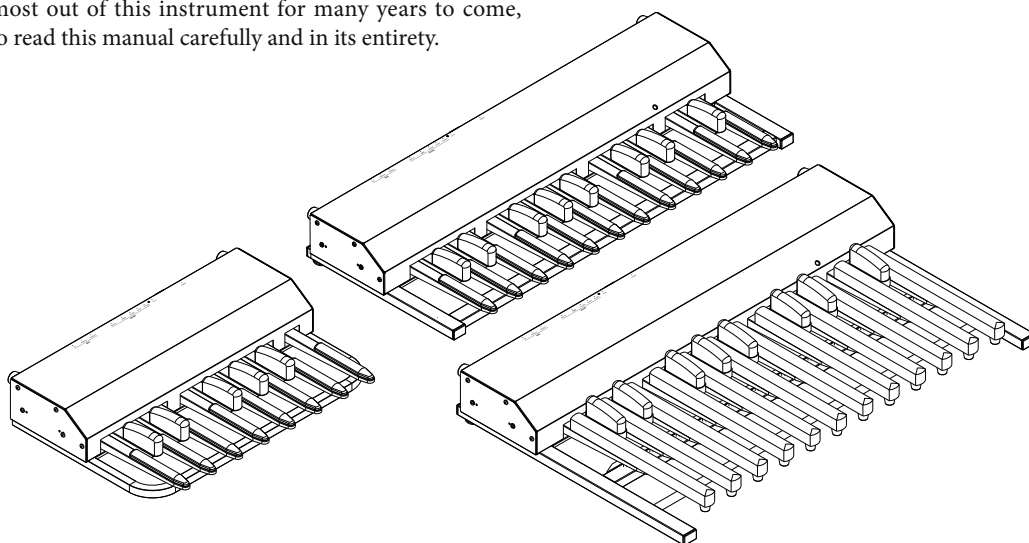

In order to get the most out of this instrument for many years to come, please take the time to read this manual carefully and in its entirety.















Owner's Manual

2 IMPORTANT SAFETY INSTRUCTIONS

- ◆ Before using this unit, please read these instructions carefully.
- ◆ Please be sure to keep this manual at hand even after reading it once.
- ◆ This "Safety Instructions" section contains very important points for securing your safety. Strictly observe the instructions, please.
- ◆ In this manual, the degrees of dangers and damages are classified and explained as follows:

	WARNING	This sign shows there is a risk of death or severe injury if this unit is not properly used as instructed.
	CAUTION	This sign shows there is a risk of injury or material damage if this unit is not properly used as instructed. **"Material damage" is defined as damage to the room, furniture or animals / pets

WARNING

-  ◆ Do not open (or modify in any way) the unit or its AC adaptor.
-  ◆ Do not attempt to repair the unit, or replace parts in it (expect when this manual provides specific instructions directing you to do so). Refer all servicing to your retailer, the nearest Hammond, or authorized Hammond distributor, as listed on the "Service" page.
-  ◆ Never use or store the unit in places that are:
 - ◆ Subject to temperature extremes (e.g., direct sunlight in an enclosed vehicle, near a heating duct, on top of heat-generating equipment)
 - ◆ Damp (e.g., baths, washrooms, on wet floors)
 - ◆ Humid
 - ◆ Exposed to rain
 - ◆ Dusty
 - ◆ Subject to high levels of vibration.
-  ◆ Be sure to use only AC adaptor supplied with the unit. Also, make sure the line voltage at the installation matches the input voltage specified on the AC adaptor's body. Other AC adaptors may use a different polarity, or be designed for a different voltage, so their use could result in damage, malfunction, or electric shock.
-  ◆ Do not excessively twist or bend the power cord, nor place heavy objects on it. Doing so can damage the cord, producing severed elements and short circuits. Damaged cords are fire and shock hazards!
-  ◆ Do not allow any objects (e.g., flammable material, coins, pins); or liquids of any kind (water, soft drinks, etc.) to penetrate the unit.
-  ◆ Immediately turn the power off, remove the AC adaptor from the outlet, and request servicing by your retailer, the nearest Hammond, or authorized Hammond distributor, as listed on the "Service" page when:
 - ◆ The AC adaptor, the power-supply cord, or the plug has been damaged; or
 - ◆ If smoke or unusual odor occurs
 - ◆ Objects have fallen into, or liquid has been spilled onto the unit; or
 - ◆ The unit has been exposed to rain (or otherwise has become wet); or
 - ◆ The unit does not appear to operate normally or exhibits a marked change in performance.
-  ◆ In households with small children, an adult should provide supervision until the child is capable of following all the rules essential for the safe operation of the unit.
-  ◆ Protect the unit from strong impact. (Do not drop it!)
-  ◆ Do not force the unit's power supply cord to share an outlet with an unreasonable number of other units. Be especially careful when using extension cords - the total power used by all units you have connected to the extension cord's outlet must never exceed the power rating (watts/amperes) for the extension cord. Excessive loads can cause the insulation on the cord to heat up and eventually melt through.
-  ◆ Before using the unit in a foreign country, consult with your retailer, the nearest Hammond, or an authorized Hammond distributor, as listed on the "Service" page.
-  ◆ Do not put anything that contains water (e.g., flower vases) on this unit. Also, avoid the use of insecticides, perfumes, alcohol, nail polish, spray cans, etc., near the unit. Swiftly wipe away any liquid that spills on the unit using a dry, soft cloth.

CAUTION



- ◆ The unit and the AC adaptor should be located so their location or position does not interfere with their proper ventilation.



- ◆ Do not stand this unit with the cables connected to it, which may cause damage to jacks and cables.



- ◆ Always grasp only the plug on the AC adaptor cord when plugging into, or unplugging from, an outlet or this unit.



- ◆ Before cleaning the unit, turn off the power and unplug the AC adaptor from the outlet.



- ◆ At regular intervals, you should unplug the AC adaptor and clean it by using a dry cloth to wipe all dust and other accumulations away from its prongs. Also, disconnect the power plug from the power outlet whenever the unit is to remain unused for an extended period of time. Any accumulation of dust between the power plug and the power outlet can result in poor insulation and lead to fire.



- ◆ Whenever you suspect a possibility of lightning in your area, disconnect the AC adaptor from the outlet.



- ◆ Try to prevent cords and cables from becoming entangled. Also, all cords and cables should be placed so they are out of the reach of children.



- ◆ Never climb on the top of, nor place heavy objects on the unit.



- ◆ Never handle the AC adaptor or its plugs with wet hands when plugging into, or unplugging from, an outlet of this unit.



- ◆ Before moving the unit, disconnect the AC adaptor and all cords coming from external units, and also remove the accessories attached to the unit.



- ◆ When transporting the unit, do not lift the unit by the pedals, which may cause damage. Use the frame to lift.

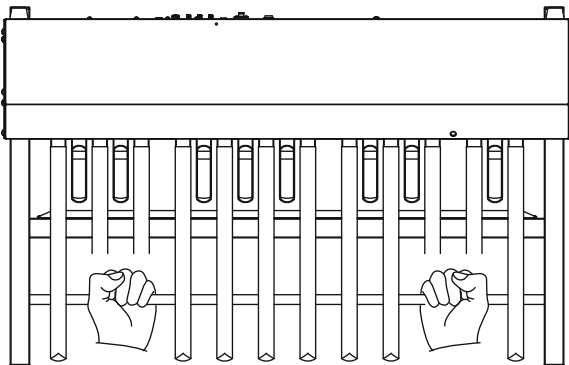

NAMES AND FUNCTIONS

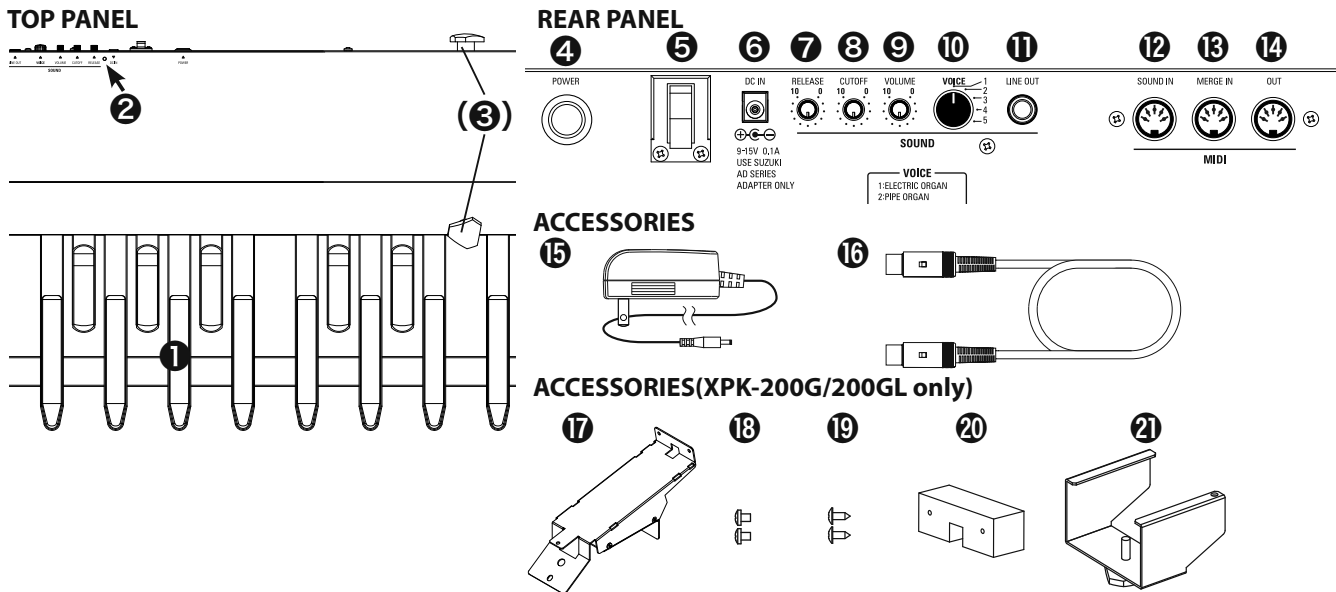

1 Pedal keyboard

Velocity-sensitive pedal keyboard. XPK-130G has 13 keys, XPK-200G/200GL both have 20 keys.

2 LED

Lights when the power is "ON," and indicates when a pedal is pressed (light will glow brighter).

3 Knob bolts(2)

Use these to fasten the 17 Expression Bracket 1.

4 POWER switch

Switches the power of this unit "ON" or "OFF." Press to turn the power "ON," press and hold for about 1 second to turn the power "OFF."

5 Cord hook

Use this hook to provide strain relief for the AC Adaptor Cord.

6 DC IN jack

Connect the 15 AC Adaptor (AD2-1210 or AD3-1210) to this jack.

7 RELEASE knob

Allows you to adjust the rate at which notes decrease to silence after key release.

8 CUTOFF knob

Allows you to change the sound or tone quality of the built-in Pedal Voices.

9 VOLUME knob

Controls the total or maximum volume of the built-in Pedal Voices (LINE OUT jack).

10 VOICE selector

Selects the built-in Pedal Voice to be sent out the LINE OUT jack.

11 LINE OUT jack

Allows you to hear the sound output from the built-in Pedal Voices through an external amplifier or powered speaker.

HAMMOND XPK-130G/200G/200GL

er. Connect an audio cable from LINE OUT to the input connectors of an external amplifier or powered speaker.

12 SOUND IN jack

Use this MIDI IN jack to play the built-in Pedal Voices of this unit from an external MIDI connection.

13 MERGE IN jack

MIDI signals received at this input will be merged with the playing information from the pedalboard, and sent out from the MIDI OUT jack.

14 MIDI OUT jack

Use this jack to send playing information of the pedalboard as well as any merged information coming from the MERGE IN jack.

ACCESSORIES

15 AC adaptor AD2-1210 / AD3-1210

DC 12V power supply which provides electrical power to this unit.

16 MIDI Cable (2.0m)

Use this cable to connect this unit to external MIDI instruments.

ACCESSORIES(XPK-200G/200GL only)

17 Expression Bracket 1

This bracket is a base for mounting the optional Expression Pedal EXP-100F, EXP-50/50J, EXP-20 or V-20R.

18 M4 x 5mm screws (2)

Use these screws for attaching the Expression Pedal EXP-100F or EXP-50/50J to 17 Expression Bracket 1.

19 ø4 x 8mm screws (2)

20 Bracket Spacer

21 Expression Bracket 2

Use these 3 parts together with the 17 Expression Bracket 1 for attaching an EXP-20 or V-20R Expression Pedal.

XPK-200G/200GL only

You can mount Hammond Expression Pedals to the XPK-200G or XPK-200GL. Please read the instructions below on how to mount your particular Hammond Expression Pedal.

Mounting the EXP-100F/50/50J

- ① Remove the screw as shown from the bottom of the Expression Pedal using a #2 Phillips screwdriver.
- ② Place the Expression Pedal on top of the Expression Bracket 1.
- ③ Fasten the Expression Pedal to the front of the bracket as shown using the two supplied M4 x 5mm screws.
- ④ Using the screw that you previously removed, fasten the Expression Pedal to the bottom of the bracket as shown.

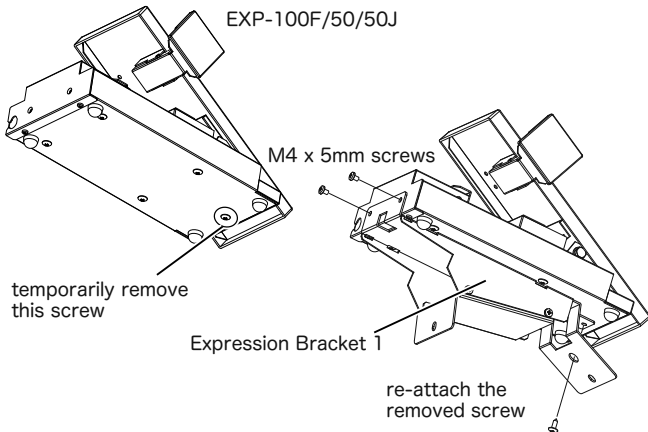

- ⑤ Place the Expression Bracket 1 on top of the XPK-200G/200GL as shown.
- ⑥ Fasten the Bracket to the XPK-200G/200GL by turning the two supplied knob bolts clockwise.

⚠ **Be sure to screw the knob bolts vertically into the panel surface. Attempting to screw into the holes diagonally may cause damage to the tapped holes.**

⚠ **Be sure that the Expression Pedal is securely fastened before playing this unit, or damage may result.**

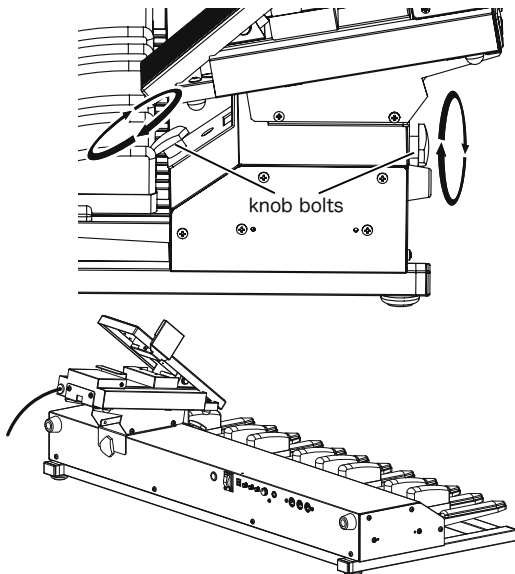

Mounting the EXP-20 or V-20R

- ① Place the Expression Bracket 1 on top of the XPK-200G/200GL as shown.
- ② Fasten the Bracket to the XPK-200G/200GL by turning the two supplied knob bolts clockwise.

⚠ **Be sure to screw the knob bolts vertically into the panel surface. Attempting to screw into the holes diagonally may cause damage to the tapped holes.**

⚠ **Be sure that the Expression Pedal is securely fastened before playing this unit, or damage may result.**

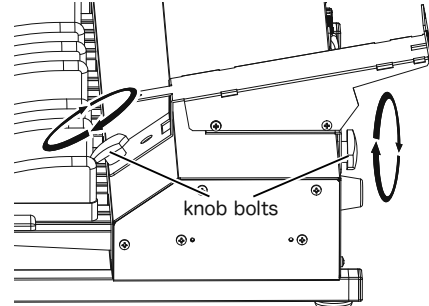

- ③ Place the Expression Pedal on top of the Expression Bracket 1 and route the cord through the hole in the Bracket as shown.

- ④ Place the Bracket Spacer on the Expression Bracket 1 as shown and fasten the spacer to the bracket with a #2 Phillips screwdriver and the 2 supplied 4 x 8mm screws.

- ⑤ Fasten the Expression Pedal to the Expression Bracket 1 by sliding the Expression Bracket 2 onto the Expression Pedal assembly as shown and turning the supplied knob bolt clockwise.

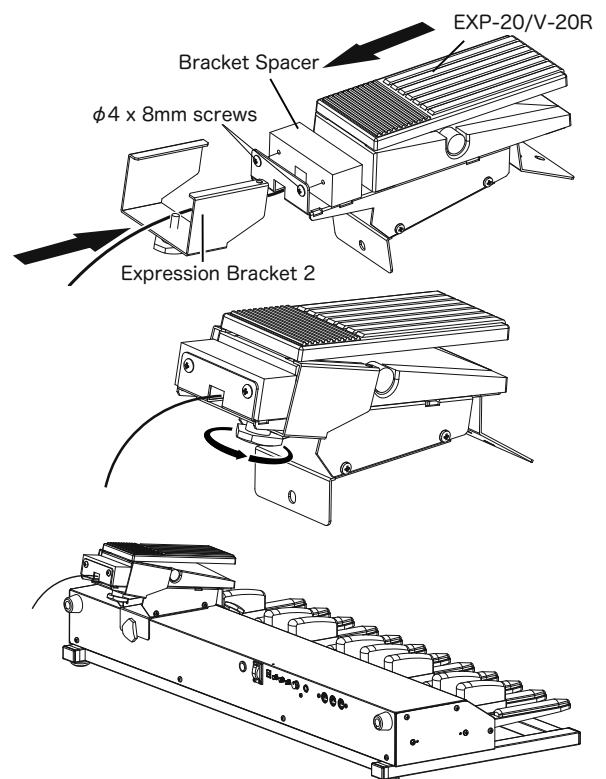

MAKING THE CONNECTIONS

Preparing unit for use

- ① Connect the AC adaptor AD2-1210/AD3-1210 into the DC IN jack on the unit.
- ② Hook the AC adaptor cord on the cord hook.
- ③ Connect the AC plug into an AC outlet.

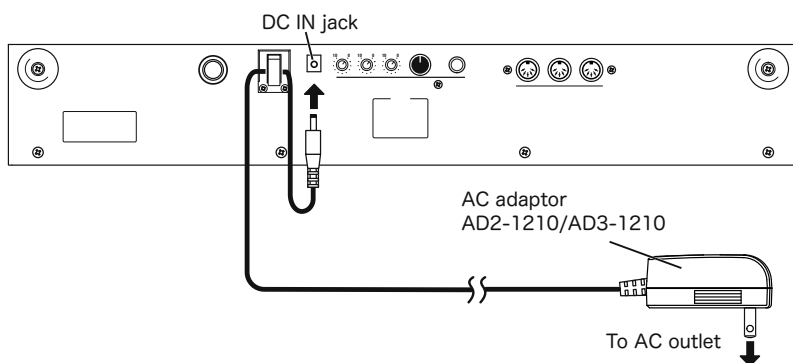

There are several ways to use this unit. Below are several examples.

Hook-up example 1: MIDI pedalboard

To use this unit as a MIDI pedalboard, do the following:

- ① Connect the MIDI OUT from the unit to the MIDI IN of the MIDI instrument you wish to use as shown.
- ② Make sure the unit and the connected instrument are set to the same MIDI Channel (factory setting is MIDI Channel 3).

NOTE: You can change the MIDI channel of this unit. See P.9.

- ③ Turn the power to the unit "ON."
- ④ In order for the connected instrument to function correctly, set the MIDI function properly. Consult the manual for your connected instrument if needed.

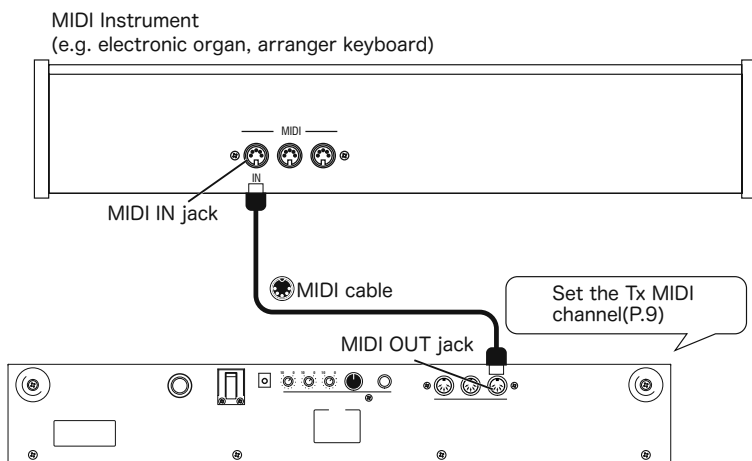

tips HOW TO TURN THE POWER ON/OFF

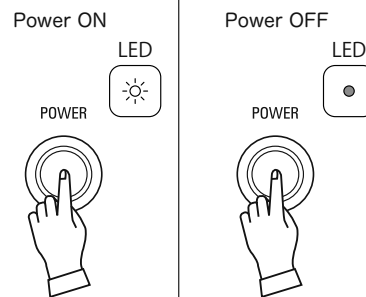

Press the POWER Switch. The power turns on and the LED will light on brightly for about 1 second.

Press and HOLD the POWER Switch for 1 second. The power turns off and the LED will light off.

⚠ Before switching the power to this unit "ON" or "OFF," be sure to set the VOLUME of both this unit and the connected amplifier etc at "0." Also, be sure the power to the connected amplifier is "OFF."

⚠ Do not connect or disconnect the audio cables while the power to both units is "ON."

tips AUTO POWER OFF

This unit has an Auto Power OFF feature which will automatically turn the power to the unit "OFF" if no notes are played or features accessed for 30 minutes (default setting).

If you wish to disable this feature please consult "Auto Power OFF" under the "ADVANCED OPERATION" section on P.10.

tips SETTING MIDI CHANNELS

To use this unit as a MIDI pedalboard, do the following:

- ① Determine to which MIDI Channel the Bass is assigned on the MIDI instrument.
- ② Set the MIDI Channel of the unit to the same channel as the Bass channel on the MIDI instrument (see the diagram below).

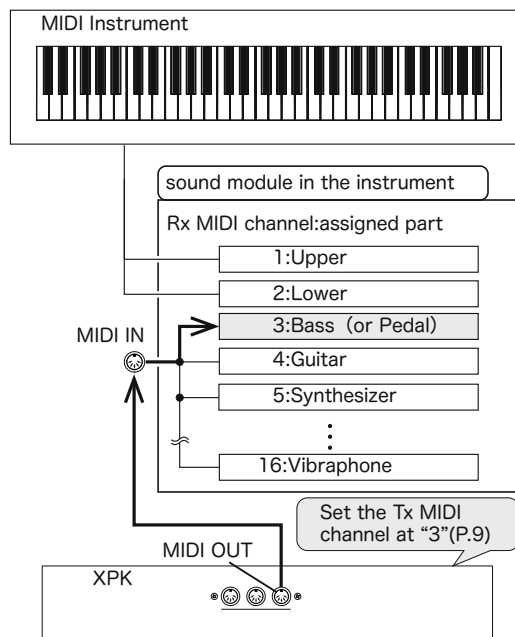

NOTE: The above example represents one possibility. The MIDI Channel assigned to Bass part may vary among different instruments.

Hook-up example 2: Bass instrument

This unit contains a built-in Sound Generator. Therefore, you can play this unit as a “stand-alone” bass instrument as well as a MIDI pedalboard.

To use the built-in Sound Generator of this unit, do the following:

- 1 Connect LINE OUT from the unit to the LINE IN of a bass amplifier, powered speaker (e.g. Leslie 2121, which is suitable for playing bass), or the LINE IN/

XPB + bass amplifier/powered speaker

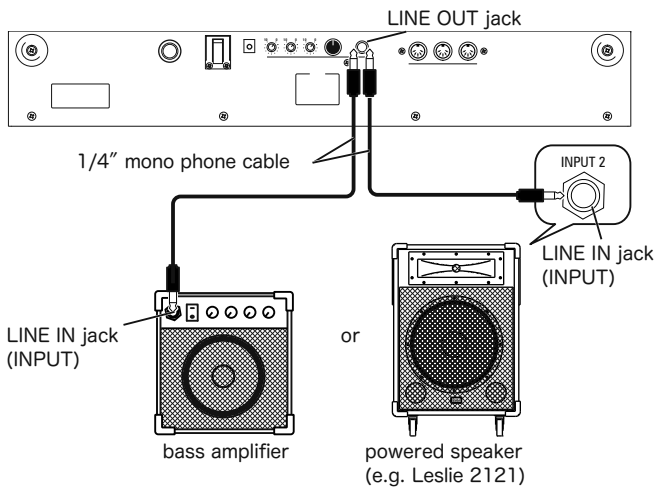

XPB + keyboard instrument

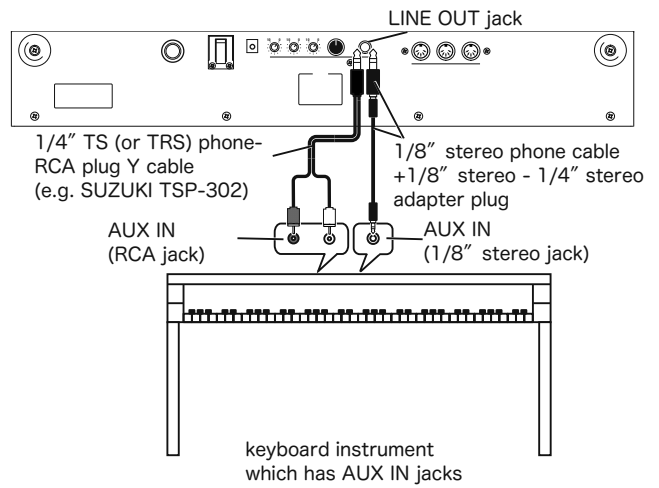

- 2 Set both the VOLUME of this unit and the equipment to which you have connected to “0.”
- 3 Turn the power to this unit “ON”, then the power to the connected equipment.
- 4 Adjust the volume of both units as desired.

NOTE: For more information on how to use the built-in Sound Generator, see P.8.

Hook-up example 3: MIDI Recording

To record and play back the performances using an external sequencer, do the following:

- 1 Connect the unit as shown in either of the figures below, depending on the type of connection you wish.
- 2 Set both the VOLUME of this unit and the equipment to which you have connected to “0.”
- 3 Make sure the unit and the sequencer are set to the same MIDI Channel (factory setting is MIDI Channel 3).

NOTE: You can change the MIDI channel of this unit. See P.9.

Using the internal Sound Generator

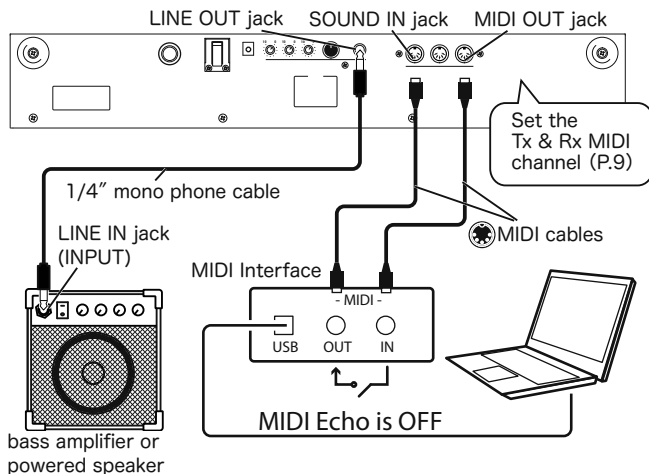

Using an external synthesizer/MIDI sound module

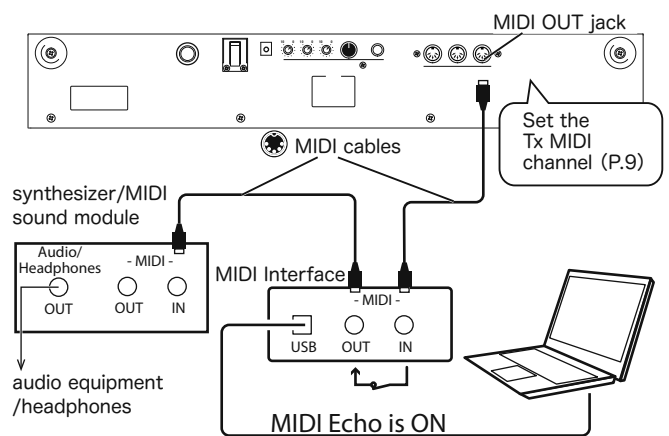

- 4 Turn the power to the unit “ON,” then the power to the equipment to which you have connected.
- 5 To avoid malfunctions due to a MIDI information loop, Set the sequencer's MIDI Echo to “OFF” as shown in the figure below on the left. If you are using the setup shown in the figure below on the right, set the sequencer's MIDI Echo to “ON” to cause the external synthesizer or module to sound.

NOTE: For more information on how to use the built-in Sound Generator, see P.8.

8 USING THE INTERNAL SOUND GENERATOR

As mentioned previously, this unit has a built-in Sound Generator. The LINE OUT jack allows you to hear the audio from the built-in Pedal Voices. The following paragraphs explain each control on the unit related to the built-in Pedal Voices.

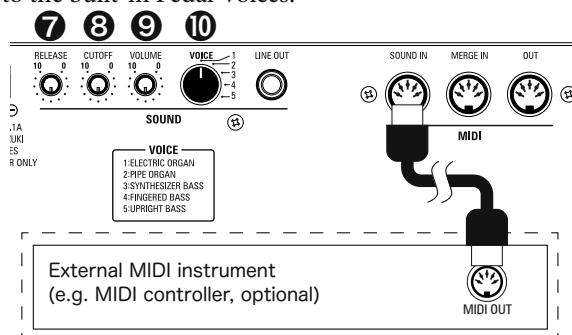

Selecting a Pedal Voice

10 VOICE selector

Allows you to select one of the following 5 built-in Pedal Voices.

- 1. ELECTRIC ORGAN** electric organ.
- 2. PIPE ORGAN** traditional pipe organ Pedal registration.
- 3. SYNTHESIZER BASS** portamento & sweeping synth bass.
- 4. FINGERED BASS** electric bass guitar.
- 5. UPRIGHT BASS** acoustic or upright bass (double bass).

Adjusting the Sound

9 VOLUME knob

Allows you to control the volume of the built-in Pedal Voices (LINE OUT). Turn this control to the right to increase the Volume, and to the left to decrease the Volume.

8 CUTOFF knob

Allows you to adjust the Cutoff Frequency. As the value is increased, the Cutoff Frequency becomes higher and the sound becomes brighter. Maximum is "10," minimum at "0."

NOTE: For details on how the cutoff works, see **tips "ADJUSTING CUTOFF"** on the right.

7 RELEASE knob (Pedal Sustain)

Allows you to determine how long a pedal note will continue to sound after a pedal is released. As the value is increased, the release time becomes longer. At "0," the tone will stop immediately when a pedal is released.

How to control the parameters by MIDI

You can also select Pedal Voices and control parameters from an external MIDI controller.

VOICE	program change #1 to 5
CUTOFF	control code #74
RELEASE	control code #72
EXPRESSION	control code #11 (crescendo and decrescendo)

NOTE: The [VOLUME] is not digitally controlled.

Connect the MIDI controller to this unit as shown above, and set the MIDI channel of the unit to the same channel as the MIDI controller. You can then send the above MIDI messages from your controller.

NOTE: You can change the MIDI channel of this unit. See P.9.

Please consult the Manual for your MIDI controller to learn how to send MIDI parameters.

tips ADJUSTING CUTOFF

The CUTOFF control will affect different sounds in different ways. This is explained more fully below.

◆ ELECTRIC ORGAN

Maximum value will give a "tone wheel" sound, while minimum value will give an "LSI" organ sound (see below).

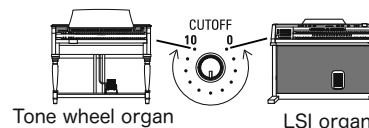

◆ PIPE ORGAN

As the value is raised, you will hear sounds being added from low to high. The effect is that of stops gradually being added on a pipe organ (see the illustration below).

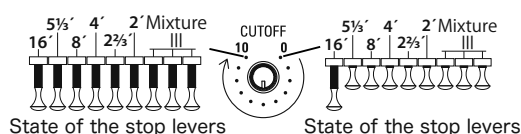

◆ Other voices

Adjust the Cutoff Frequency. The more the value is raised, the higher the Cutoff Frequency will be.

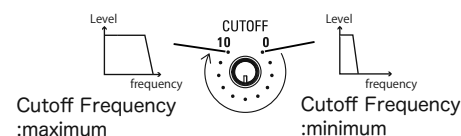

tips ADJUSTING RELEASE

The RELEASE knob works as follows.

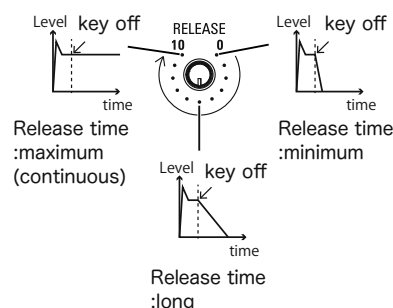

tips RANGE OF EACH PEDAL VOICE

As shown in the diagram below, the Note Ranges of the Pedal Voices are the same in all units; however, both the XPK-200G and the XPK-200GL will sound seven (7) more notes than the XPK-130G because of the expanded number of pedal notes.

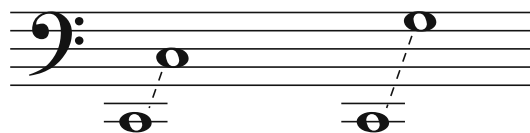

Range of Voices 1 to 5 on XPK-130G

Range of Voices 1 to 5 on XPK-200G/200GL

NOTE: Actual sound range is 1 octave lower than the notes written in the diagram above.

NOTE: Although this unit has only 13 or 20 notes, the built-in Pedal Voices can sound 4 full octaves (Note numbers 36 through 84) via SOUND IN.

Setting the MIDI channel

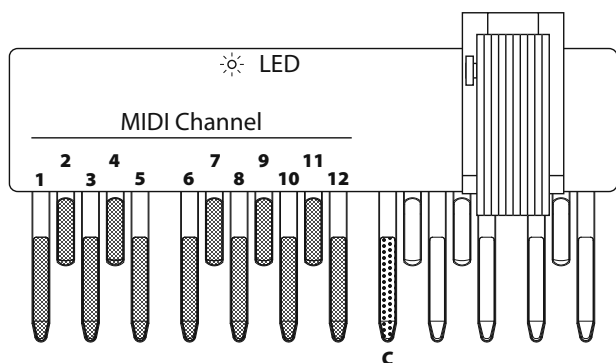

This Advanced Feature allows you to change the MIDI Channel on which the unit transmits and receives. You can select from “1” through “12.” The default setting is Channel “3.”

To change the MIDI Channel, do the following:

NOTE: Doing the procedure below will set both the transmitting and receiving MIDI Channel of the unit - in other words, you cannot set different MIDI IN and MIDI OUT Channels.

- ① Press and Hold the high “C” pedal and the pedal corresponding with the MIDI channel you want (see the diagram on the left).
- ② Continue to hold the pedal keys and turn the power to the unit “ON.”

The LED light on this unit will blink the same number of times as the number of the MIDI channel selected, indicating that the MIDI channel has been changed.

NOTE: This setting will be remembered even if the power to the unit is turned “OFF.”

The MIDI MERGE function

This unit is equipped with the MIDI MERGE function. This feature allows MIDI playing information received at the MERGE IN jack to be merged (blended) with the MIDI information from this unit and sent out from the MIDI OUT jack.

⚠ Important notes on MIDI Merge

When you use the MIDI MERGE function, PLEASE NOTE several points.

The MIDI messages to be merged

The MIDI MERGE function of this unit will only merge the channel messages. It does not merge system messages such as System Exclusive (SysEx) data or MIDI Clock data.

Duplication of the MIDI channel

The Channels assigned to the MERGE IN must be different than the channel of the Pedalboard in order to provide correct data to the host keyboard.

The MIDI loop

If the MIDI information sent out the MIDI OUT jack of this unit returns to the MERGE IN jack or SOUND IN jack, a MIDI information loop occurs, causing a malfunction.

If the MERGE IN (or SOUND IN)/MIDI OUT of this unit and MIDI OUT/MIDI IN of the external equipment are connected, set the MIDI Echo function or the Local Control function of the external equipment to “OFF” to correct the problem.

tips 3 KEYBOARDS USING MIDI MERGE

To connect 3 keyboards (Upper and Lower Manuals plus Pedals), connect both this unit and another MIDI keyboard to the mother keyboard using the MIDI MERGE function, even if the mother keyboard has only one MIDI IN jack. See the diagram below.

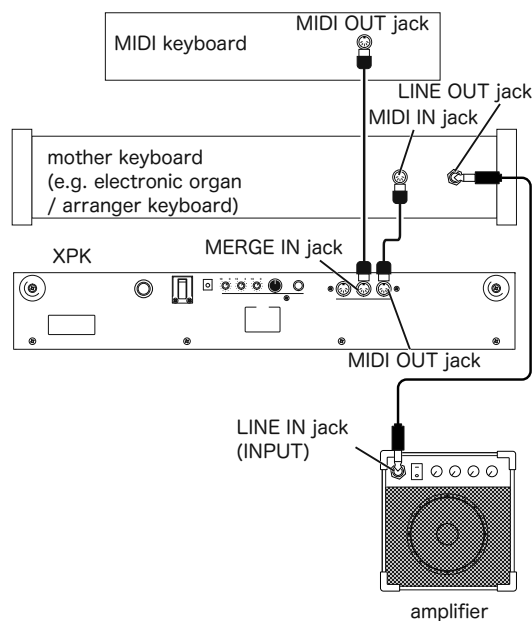

ADVANCED OPERATION

You can customize the operation of this unit with these Advanced Features.

NOTE: These settings will be remembered even if the power to the unit is turned "OFF."

Auto Power OFF

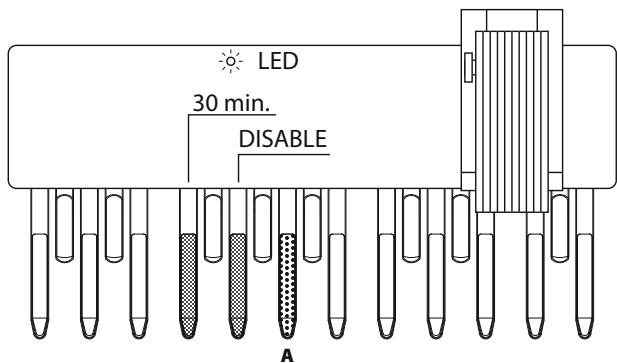

This allows you to select whether the unit will automatically turn "OFF" after 30 minutes, or stay "ON" continuously.

The default setting is "30 min."

To set this feature, do the following:

- 1 Press and HOLD the "A" pedal key and the pedal corresponding to the setting value (see the diagram on the left). "30 min." and "DISABLE" are available.

30 min. The unit will turn "OFF" automatically if not played or operated for 30 minutes.

DISABLE The unit will stay "ON" continually.

- 2 Continue to hold the pedal keys and turn the power to the unit "ON."

The LED on the top panel will blink 5 times, indicating that Auto Power OFF function setting has been changed.

Velocity Curve

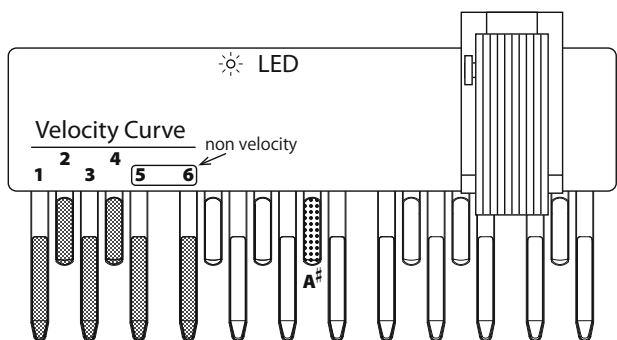

This allows you to determine how the notes will respond to key velocity. You can select "1 ~ 6". The default setting is "5" (standard organ touch - the notes sound at the same volume regardless of a light or heavy note pressure), "1" is the most exaggerated velocity curve while "4" is a gentler curve. "2" and "3" are curves in between.

To select a Velocity Curve, do the following:

- 1 Press and Hold the "A#" pedal key and the pedal corresponding to the Velocity-Curve you want (see the diagram on the left).

- 2 Continue to hold the pedal keys and turn the power to the unit "ON."

The LED on the top panel will blink according to the value you select, indicating that the Velocity-Curve has been changed.

tips VELOCITY CURVE

A graphic of each Velocity Curve is shown below. Curve 1 is the most faithful to the actual pressing velocity, while at Curve 5 or 6, you can play with fixed velocity.

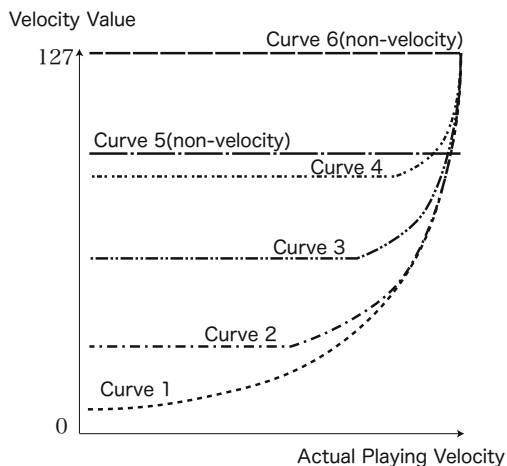

Master Tune

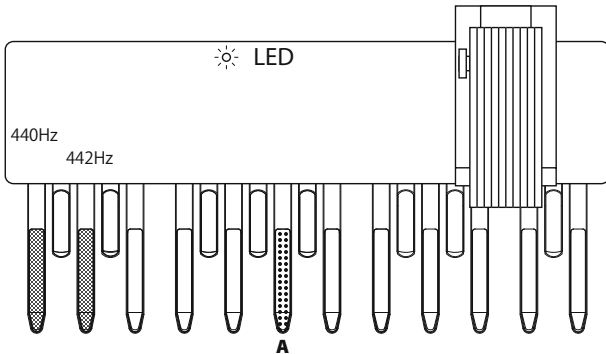

This allows you to change the master tuning of the built-in Sound Generator. You can select either “A=440Hz” or “A=442Hz.” The default setting is “A =440Hz.”

To change the Master Tune, do the following:

- ① Press and HOLD the “A” pedal key and the pedal corresponding to the master tuning frequency (see the diagram on the left).
- ② Continue to hold the pedal keys and turn the power to the unit “ON.”

The LED on the top panel will blink three times, indicating that the unit’s master tuning frequency has been changed.

LED Brightness

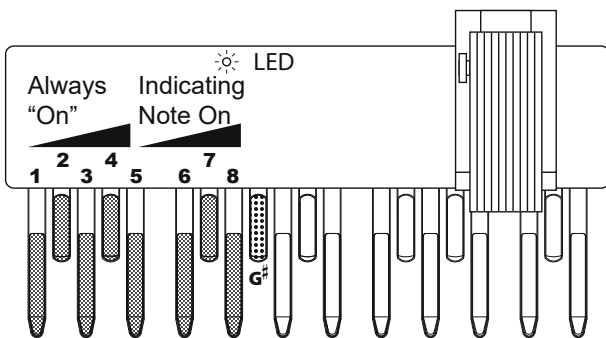

This allows you to adjust the brightness level of the LED on the top panel. You can select from “1” (dim, always on) through “8” (bright, indicating Note On). The default setting is “8.”

To change the LED Brightness, do the following:

- ① Press and HOLD the “G#” pedal key and the pedal corresponding to the brightness level you want (see the diagram on the left).
- ② Continue to hold the pedal keys and turn the power to the unit “ON.”

The LED on the top panel will blink according to the value you select, indicating that the LED brightness level has been changed.

Load Default Values

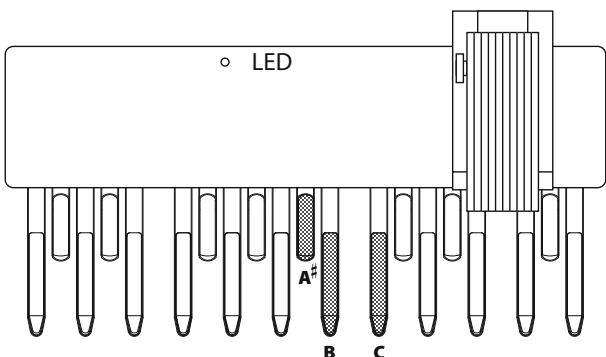

To restore the factory default settings of this unit, do the following:

- ① Press and Hold the “A#”, “B” and high “C” pedals (see the diagram on the left).
- ② Continue to hold the pedal keys and turn the power to the unit “ON.”

The LED on the top panel will light momentarily then turn off for a second, indicating that the unit’s factory settings have been restored.

MIDI IMPLEMENTATION CHART

Hammond MIDI sound pedalboard
Model:
XPK-130G/XPK-200G/XPK-200GL

MIDI Implementation Chart

Date: 23-Jun.-2017
Version: 1.0

Function		Transmitted	Recognized	Remarks
Basic Channel	Default Changed	3 1 - 12	3 1-12	
Mode	Default Messages Altered	3 X *****	4 X X	
Note Number	: True Voice	36 - 48 36-55 *****	36-84 36-84	XPK-130G XPK-200G/200GL
Velocity	Note ON Note OFF	O X	O X	
After Touch	Key's Ch's	X X	X X	
Pitch Bend		X	X	
Control Change	11	X	O	Expression Release Cutoff
	72	O	O	
	74	O	O	
Program Change	: True #	O 0 - 4	O 0 - 4	Voice 1 - 5
System Exclusive		X	X	
System Common	: Song Position : Song Select : Tune	X X X	X X X	
System Real Time	: Clock : Commands	X X	X X	
Aux Messages	: All Sounds Off	X	O	(120)
	: Reset All Controllers	X	X	(121)
	: Local On/Off	X	X	
	: All Notes Off	X	O	(123 - 127)
	: Active Sense	O	O	
	: Reset	X	X	

Mode 1: OMNI ON, POLY Mode 2: OMNI ON, MONO
Mode 3: OMNI OFF, POLY Mode 4: OMNI OFF, MONO

O: Yes
X: No

SPECIFICATIONS

	XPk-130G	XPk-200G	XPk-200GL
Sound Generator	Virtual Analog Sound Generator (monophonic, 24bit 32kHz)		
Keyboards	Velocity-sensitive 13-note	Velocity-sensitive 20-note	Velocity-sensitive, wooden naturals*1 20-note
Connections	DC IN, MIDI OUT, MERGE IN, SOUND IN, LINE OUT		
User Controls	VOICE, VOLUME, CUTOFF, RELEASE		
Dimensions*2	560(W) x 400(D) x 105(H)mm 22" (W)x 15.7" (D)x 4.1" (H)	872(W) x 400(D) x 115(H)mm 34.3" (W)x 15.7" (D)x 4.5" (H)	872(W) x 560(D) x 115(H)mm 34.3" (W)x 22" (D)x 4.5" (H)
Weight*2	7.7kg, 16lbs	12.7kg, 28lbs	15.4kg, 33lbs
Accessories	AC adaptor AD2-1210(120V)/ AD3-1210(220-240V) MIDI cable (2.0m)	AC adaptor AD2-1210 (120V)/AD3-1210 (220 - 240V) MIDI cable (2.0m) Expression Bracket 1,2 M4 x 5mm screws (2) ø4 x 8mm screws(2) Bracket Spacer	

*1 White keys only.

*2 Excluding accessories.

For the USA



◆ NOTE: This equipment has been tested and found to comply with the limits for a Class B digital unit, pursuant to part 15 of the FCC Rules. These limits are designed to provide reasonable protection against harmful interference in a residential installation. This equipment generates, uses and can radiate radio frequency energy and, if not installed and used in accordance with the instructions, may cause harmful interference to radio communications. However, there is no guarantee that interference will not occur in a particular installation. If this equipment does cause harmful interference to radio or television reception, which can be determined by turning the equipment off and on, the user is encouraged to try to correct the interference by one or more of the following measures:

- ◆ Reorient or relocate the receiving antenna.
- ◆ Increase the separation between the equipment and receiver.
- ◆ Connect the equipment into an outlet on a circuit different from that to which the receiver is connected.
- ◆ Consult the dealer or an experienced radio/TV technician for help.

For CANADA

- ◆ This class B digital apparatus complies with Canadian ICES-003.
- ◆ Cet appareil numérique de la classe B est conforme à la norme NMB-003 du Canada.

For EU countries



◆ In case in the future your instrument gets too old to play/use or malfunctions beyond repair, please observe the instructions of this mark, or, if any question, be sure to contact your dealer or your nearest town or municipal office for its proper disposal.

Hammond maintains a policy of continuously improving and upgrading its instruments and therefore reserves the right to change specifications without notice. Although every attempt has been made to insure the accuracy of the descriptive contents of this Manual, total accuracy cannot be guaranteed.

Should the owner require further assistance, inquiries should first be made to your Authorized Hammond Dealer.

If you still need further assistance, contact Hammond at the following addresses:

In the United States contact:

Hammond Suzuki USA, Inc.

743 Annoreno Drive, Addison, Illinois 60101 USA

TEL:(630) 543-0277 FAX:(630) 543-0279

Web site: www.hammondorganco.com / E-mail: info@hammondorganco.com

Product Registration

<http://hammondorganco.com/support/online-product-registration/>



In European countries contact:

Hammond Suzuki Europe B.V.

Ir. D. S. Tuynmanweg 4a 4131 PN Vianen The Netherlands

TEL: (+31) 347-370594

Web site: www.hammond.eu / E-mail: info@hammond.eu

Product Registration

<http://www.hammond.eu/support/online-product-registration/>



Please contact Suzuki Corporation for other countries.

Suzuki Corporation

2-25-11, Ryoke, Naka-ku, Hamamatsu, Shizuoka Pref. 430-0852 Japan

TEL : +81 53 460 3781 FAX : + 81 53 460 3783

E-mail: suzukicorp@suzuki-music.co.jp

Technical materials are available and can be obtained either by e-mail or by mailing a request to the appropriate address listed above marked ATTENTION: SERVICE DEPARTMENT.

Manufacturer :

SUZUKI MUSICAL INST. MFG. CO., LTD.

2-25-12, Ryoke, Naka-ku, Hamamatsu, Shizuoka Pref. 430-0852 Japan

TEL : +81 53 461 2325 FAX : + 81 53 463 5858